

# ▲ PEAKTRONICS

The Peaktronics DMC-101 DC Motor Controller is used for proportional positioning of actuators that use either DC motors or DC solenoids. The wide operating range of the DMC-101 (10 to 30 VDC and loads up to 10A locked rotor for 20 seconds typical) allows operation in a variety of applications. An external command signal of 4-20mA is used to compare to a feedback signal from a potentiometer. The MOTOR 1 (*open*) or MOTOR 2 (*close*) output will energize, which powers the actuator motor or solenoids, until the feedback signal matches the command signal, at which time the controller's motor output is turned off and the actuator stops.

The unit has on-board LED indicators that show which direction the DMC-101 is attempting to move the actuator. The red LED comes on when the unit is attempting to move the actuator toward *open*. Conversely, the green LED comes on when the unit is attempting to move toward *closed*. When the command signal is lost or disconnected, the *close* output will turn on.

Non-interactive Zero and Span adjustments allow easy field calibration, and the Deadband adjustment allows control of faster actuators. The unit includes a yellow LED indicator (showing the presence of the 4-20mA command signal), a red LED indicator (for the *open* output), a green LED (for the *close* output), and an on-board replaceable fuse (TR5 type, 6.3A time lag 374 Series).

Its solid construction body makes it rugged and easy to mount (two #6 through holes are provided). Screw terminals and a wiring diagram on the unit allow for easy field installation.

## ADDITIONAL FEATURES

- Capable of using the full range of the feedback potentiometer.
- 4-20mA input has built-in current limiting and reverse polarity protection.
- Optical isolation between the input signal and the DC outputs
- Dynamic braking eliminates need of mechanical brake to avoid motor coasting.
- Low standby current (22mA typical) when actuator is not in operation.

## DMC-101

DC Motor Controller, 10A



DMC-101

- Limit switch inputs referenced to ground allows optional limit indicators with form-C limit switches.
- Compatible with XMA-105 4-20mA Feedback Position Transmitter
- Miniature size fits in the smallest actuators.
- Operating temperature range of 0 to 60 °C

## OUTLINE

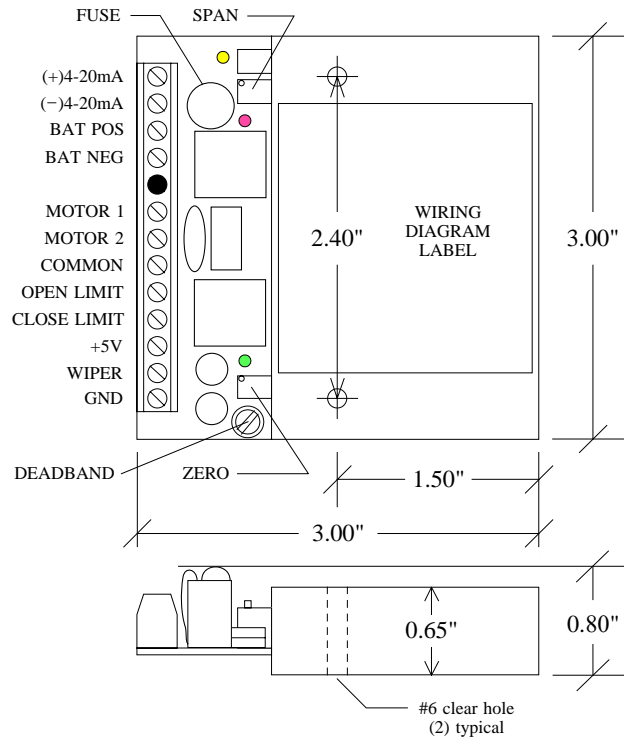

## BLOCK DIAGRAM

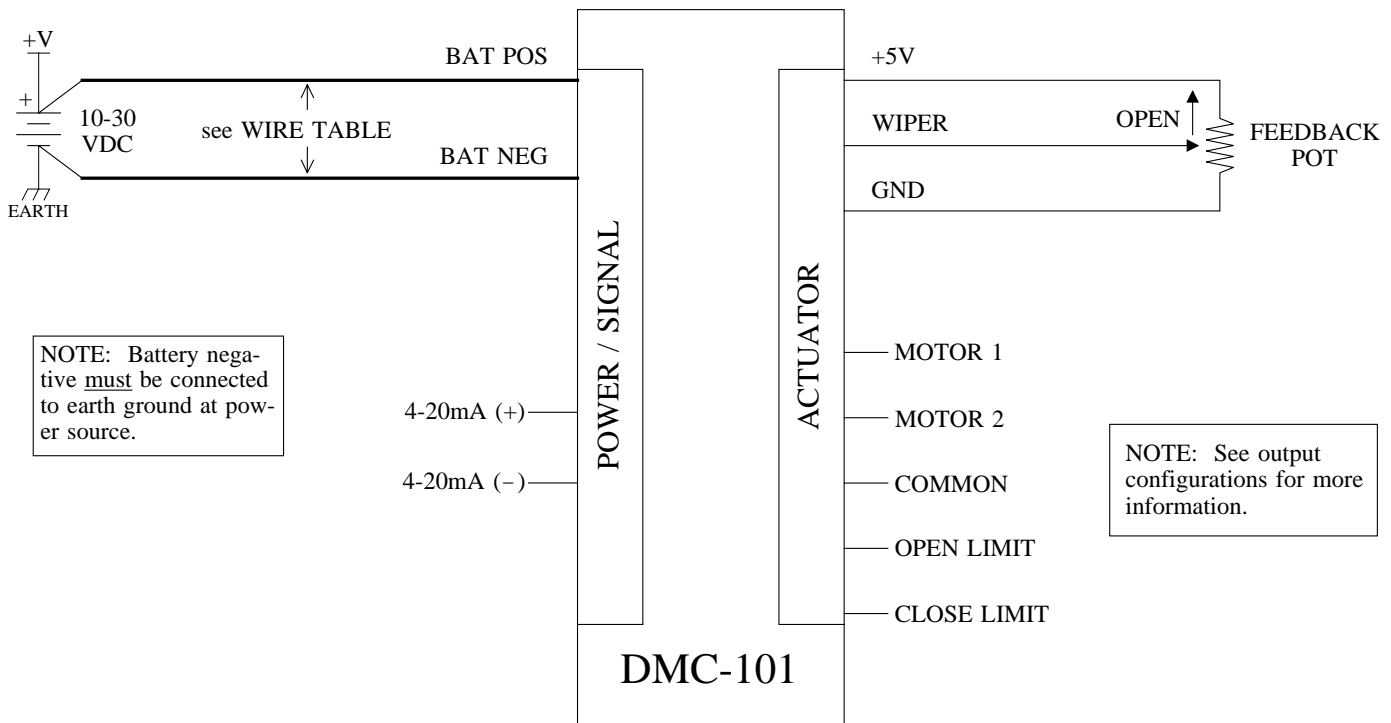

NOTE: Battery negative must be connected to earth ground at power source.

NOTE: See output configurations for more information.

## DESCRIPTION

The DMC-101 is equipped with screw terminals, allowing for easy field wiring. The unit also has a label that provides convenient information for wiring and locating the adjustments. Two mounting holes are provided that allow easy mounting with standard #6 screws. See Outline information for more details.

**Electrical Hazard!** These units are intended to be mounted in an appropriate enclosure connected to earth ground through wiring or piping. Although the hazards of an electrical shock are reduced with the use of low voltage DC power sources the high currents available can be quite damaging, so the power source should be disconnected prior to any wiring of these units.

**Outdoor Consideration!** A heater and thermostat should be used where low temperatures and/or condensation may occur. Installing a clay based desiccant packet at the time of final access prior to sealing the cover is highly recommended. This will reduce the dew and frost points by reducing the relative humidity inside the actuator.

### POWER

The positive terminal of the DC power source is connected to the BAT POS terminal while the negative terminal of the source connects to the BAT NEG terminal (see Block Diagram). Transferring DC power can be inefficient, therefore care should be taken to use appropriate wire sizes. The size wire required depends on the locked rotor motor current and the length of wire to be used. See the Wire Table for more information.

### MOTOR and FEEDBACK POT

The MOTOR 1 and MOTOR 2 terminals should be connected to a DC motor so that the actuator moves toward the *open* position with MOTOR 1 being positive. Conversely, the actuator should move toward the *closed* position when MOTOR 2 is positive. When powering solenoids, connect MOTOR 1 to the solenoid that moves the actuator toward *open*, while MOTOR 2 is connected to the solenoid that moves the actuator toward *closed*.

Internally, the DMC-101 connects MOTOR 1 to BAT POS and MOTOR 2 to BAT NEG when attempting to move the actuator toward the *open* position. The opposite occurs when the DMC-101 attempts to move the actuator toward the *closed* position. Since MOTOR 1 and MOTOR 2 are alternately connected to BAT NEG and BAT POS, care should be taken not to connect these outputs to any other terminals.

The DMC-101 provides a dynamic braking feature that eliminates the need for a separate brake. When the DMC-101 turns off the motor outputs, MOTOR 1 and MOTOR 2 are internally connected to BAT NEG; this has the effect of shorting the motor leads together, thus braking the motor motion. This condition also holds true when power is removed from the DMC-101. In some applications, a brake is required for mechanical reasons, such as avoiding back driving the motor; the DMC-101 is suitable for powering most brakes, however, consult the actuator manufacturer for more information.

Many actuators include limit switches that are used to turn off the motor when the extreme ends of travel have been reached. Limit switches should be wired to the OPEN LIMIT, CLOSE LIMIT, COMMON terminals (see Wiring Diagrams, Output Configurations). If limit switches are not used, OPEN LIMIT and CLOSE LIMIT must be connected to COMMON; if this is not done, the DMC-101 will not be able to control the motor outputs.

The feedback potentiometer wiper must be connected to the WIPER terminal. One end of the potentiometer is connected to the +5V terminal, and the other is connected to the GND terminal. The potentiometer should be connected so that when the actuator moves towards the *open* position, the potentiometer's resistance between the WIPER and GND terminals will increase. This can also be measured as a voltage - the voltage between the WIPER and GND terminals should increase when the actuator moves towards the *open* position. If the potentiometer is wired incorrectly, the typical response of the unit will be to run the actuator to the full open or closed position (the appropriate output indicator will remain on) regardless of the command signal input.

The feedback potentiometer should be mounted to provide a proper feedback signal through the entire range between the *open* and *closed* positions. For best results, position the actuator to the midway point between the *open* and *closed* positions; then adjust the feedback potentiometer for approximately 2.5 VDC (or 1/2 of the potentiometer's resistance) between the WIPER and GND terminals.

Since the feedback potentiometer is crucial for proper operation of the DMC-101, the following items should be carefully observed:

- 1 - Potentiometer resistance should be a value from 1K to 10K ohms.
- 2 - The potentiometer should be a linear taper type.
- 3 - The potentiometer must be properly wired to provide the correct feedback signal.
- 4 - The potentiometer must be properly and securely mounted in order to provide a reliable feedback signal.

## COMMAND INPUT and INDICATOR

The DMC-101 is designed to be controlled with a standard 4-20mA signal. The input is optically isolated from the DC power line and includes built-in current limiting and protection against reverse polarity. The input can be connected in series with any part of the current loop (sinking or sourcing outputs).

The unit is equipped with a yellow indicator that will turn on whenever the 4-20mA signal is connected. If the input signal is lost, the indicator will turn off, and the *close* output will turn on (moving the motor to the full closed position).

## OUTPUT INDICATORS

The DMC-101 has on-board LED indicators that identify when one of the motor outputs is turned on. When the MOTOR 1 output is turned on, the red LED will turn on to indicate that the unit is trying to power the actuator toward *open*. When the MOTOR 2 output is turned on the green LED will turn on to indicate that the unit is trying to power the actuator toward *closed*. See the Outline drawing for location of the LED's.

Many actuators are equipped with limit switches at the *open* and *closed* positions which are intended to disconnect power to the motor to prevent mechanical damage. For this reason, it is possible that the DMC-101 will indicate that one of the motor outputs is turned on when the actuator is not in motion.

## CALIBRATION

The non-interactive zero and span adjustments of the DMC-101 allows for easy calibration once the unit is installed. After insuring that the feedback potentiometer and motor outputs are wired to provide a proper feedback signal, as described under "MOTOR and FEEDBACK POT", follow these steps to calibrate the unit (see Outline for the location of the adjustments):

- 1 - Apply DC power to the unit, and set the command input signal to 4 mA.
- 2 - Adjust the "Zero" adjustment so that the actuator moves to the desired *closed* position. If the desired position cannot be achieved, check that the feedback potentiometer provides a feedback signal as described under "MOTOR and FEEDBACK POT"; also, check the position of the limit switches.
- 3 - If the actuator is hunting for position, turn the "Deadband" adjustment clockwise until hunting stops. If the actuator is not hunting for position, turn the "Deadband" adjustment counterclockwise

until the actuator begins to hunt; then turn the "Deadband" adjustment slightly clockwise until hunting stops.

**WARNING!** Actuator failure may occur if the "Deadband" adjustment is set to allow continuous hunting. This can cause excessive wear of motor bearings, gear train, dynamic brake, and feedback potentiometer. Hunting can also cause the internal temperature of the actuator housing to rise to a level that exceeds the maximum rating of the DMC-101, 60°C.

- 4 - Set the command signal input to 20 mA.
- 5 - Adjust the "Span" adjustment so that the actuator moves to the desired *open* position. If the desired position cannot be achieved, check the position of the limit switch.  
**NOTE:** The "Zero" adjustment is an offset setting rather than an absolute setting. Should the "Zero" adjustment be changed, the "Span" adjustment should be checked for the desired *open* position. Setting of the "Span" adjustment has no affect on the "Zero" adjustment.
- 6 - To check proper operation and linearity, set the command signal to 12 mA, and verify that the actuator's position is midway between the *open* and *closed* positions.

## REVERSE ACTING CALIBRATION

When converting a direct acting actuator to a reverse acting actuator, three changes in wiring must be made:

- 1 - Reverse the feedback potentiometer wires connected to +5V and GND.
- 2 - Reverse the motor wires connected to MOTOR 1 and MOTOR 2.
- 3 - Reverse the limit switch wires connected to the OPEN LIMIT and CLOSE LIMIT terminals.

**NOTE: DO NOT** reverse the input signal polarity.

After the wiring changes have been made, refer to **CALIBRATION** for setting the zero and span adjustments.

## WIRING DIAGRAMS

### Output Configurations

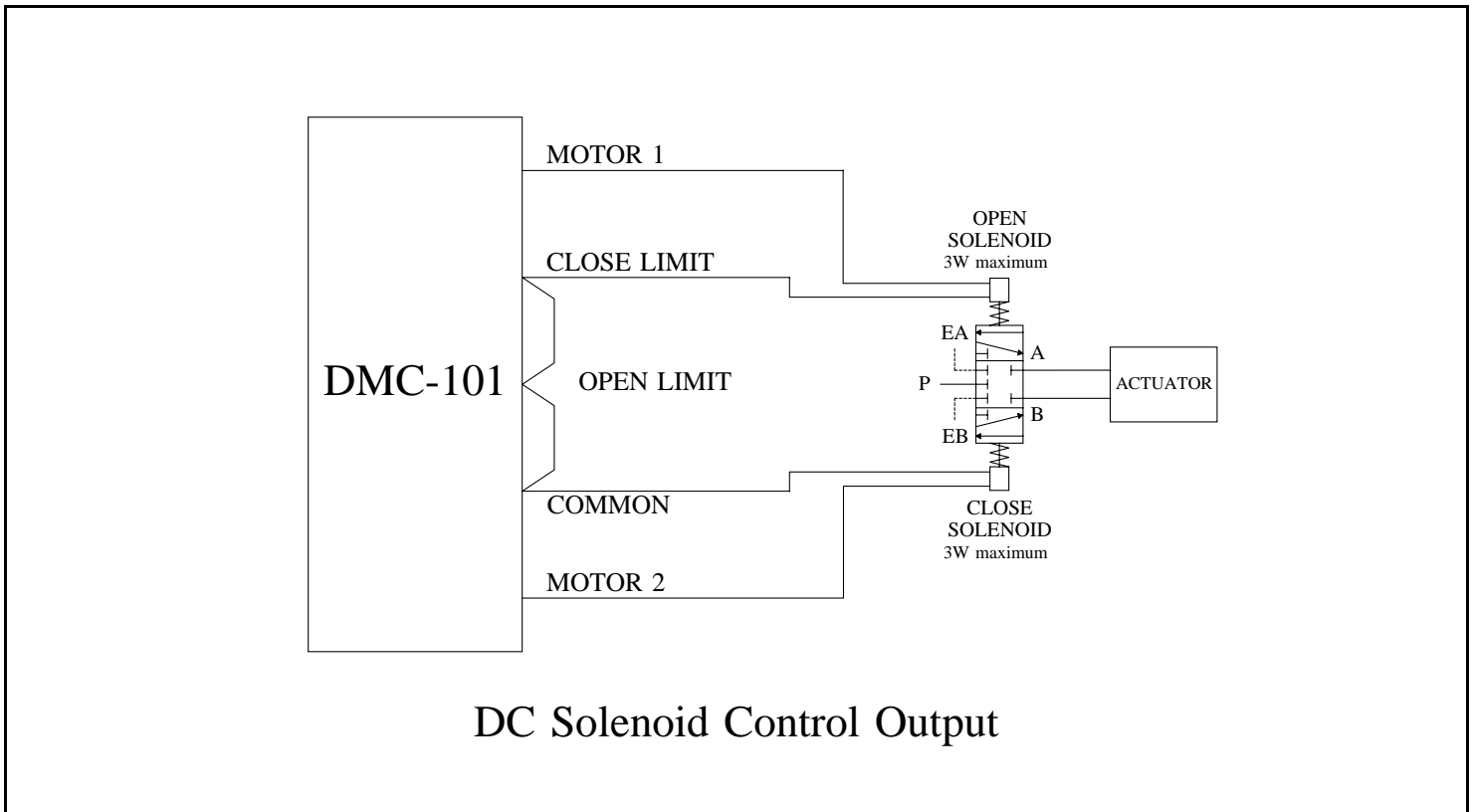
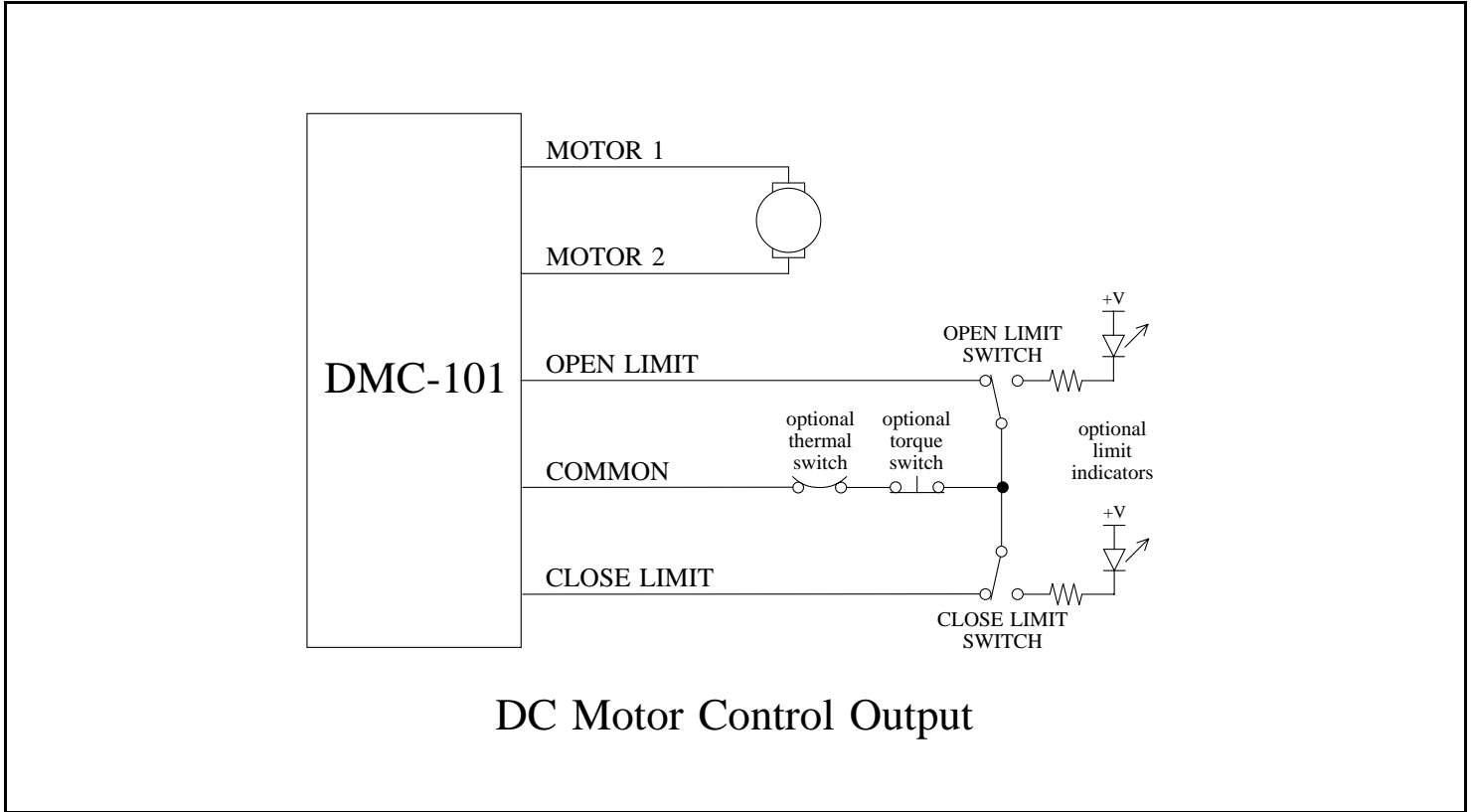

## WIRING DIAGRAMS

### Special Applications

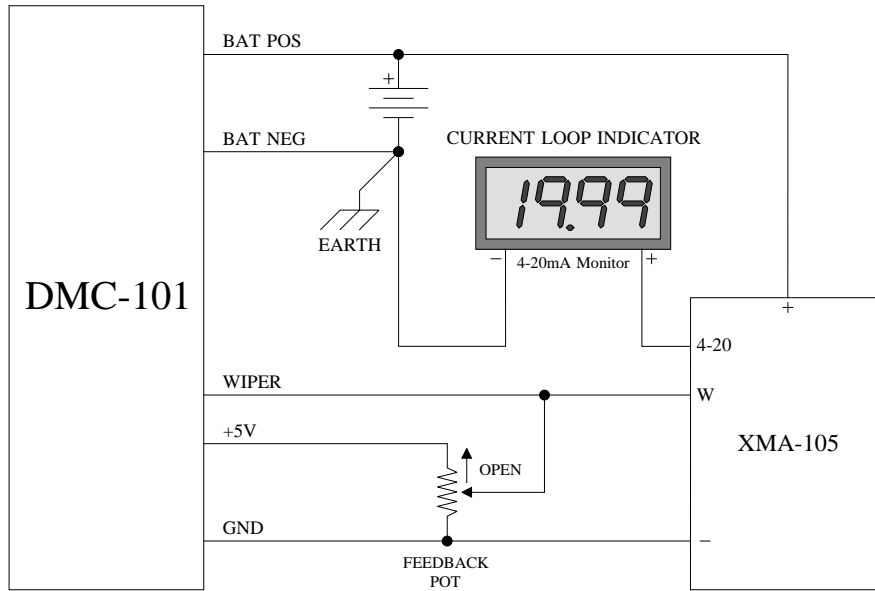

**Connecting a Position Feedback Transmitter**

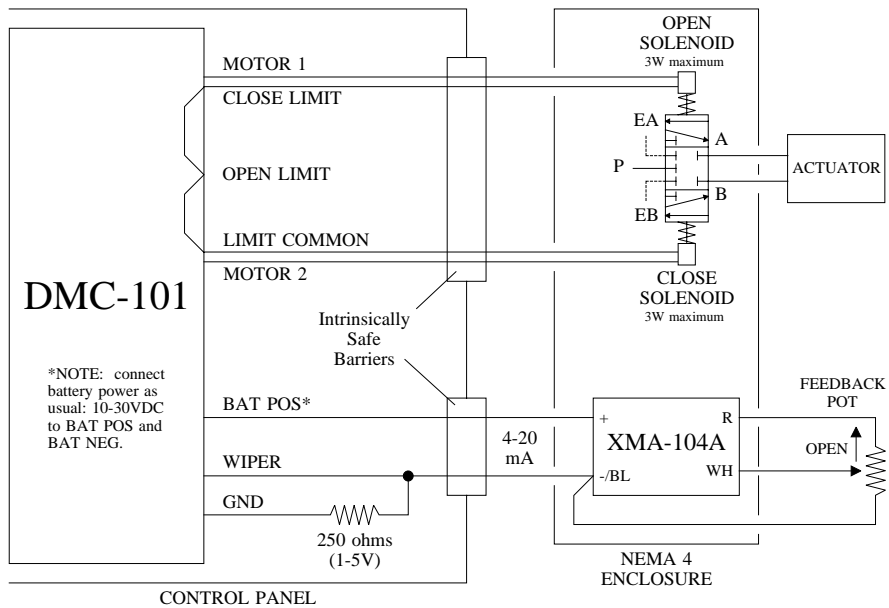

**Intrinsically Safe Solenoid Controller**

## WIRING DIAGRAMS

### Special Applications

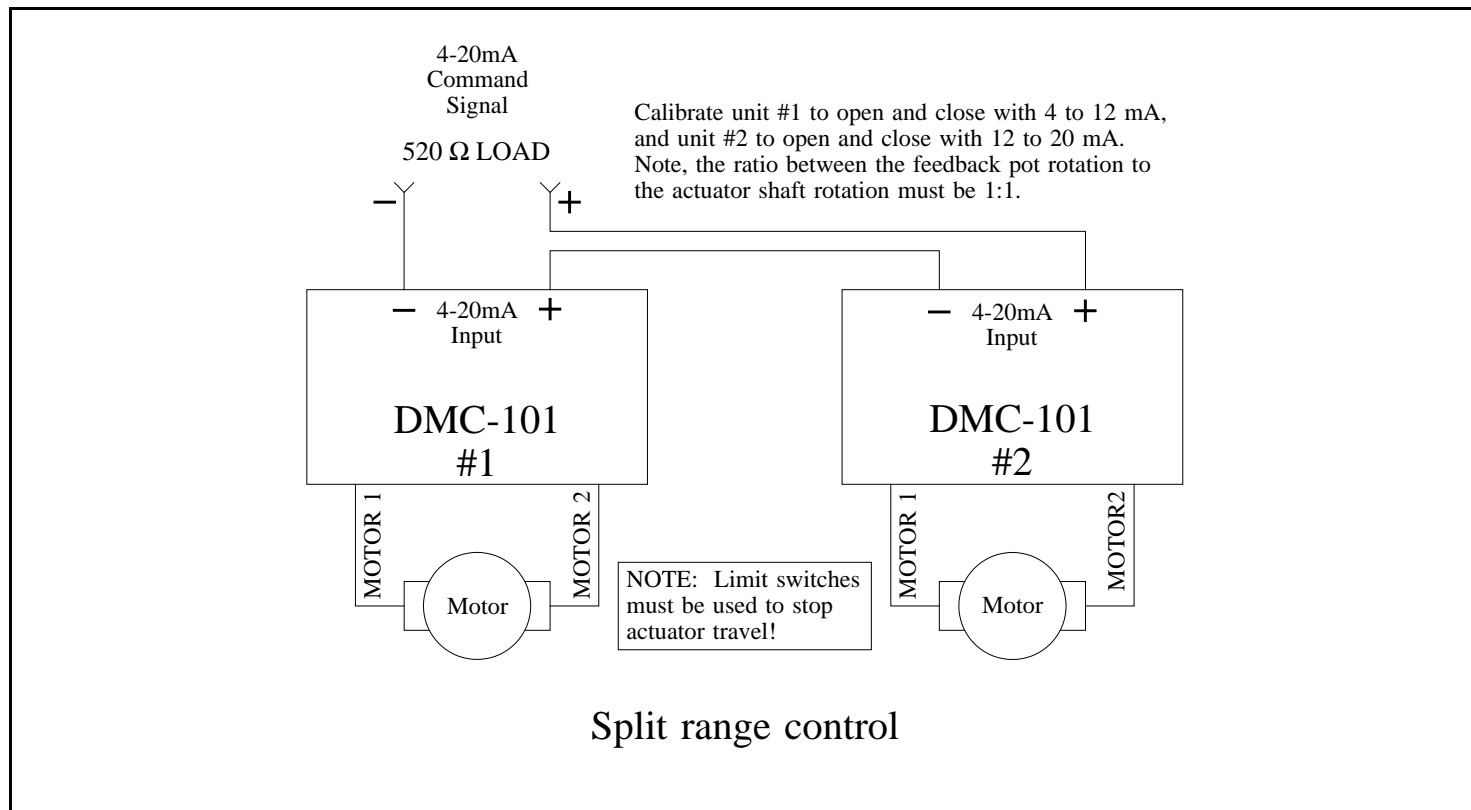

## WIRE TABLE

The table below shows the maximum recommended distance (in linear feet) between the battery source and the DMC-101 unit. The maximum distance is limited by the wire size used and the locked rotor current of the motor. All signal wires on the DMC-101 should be connected with wires sizes ranging from 22 to 18 AWG.

ft	Wire Size						
Locked Rotor Current (Amps)	18 AWG	16 AWG	14 AWG	12 AWG (see Note 1)	10 AWG (see Note 1)	8 AWG (see Note 1)	6 AWG (see Note 1)
1	133	211	337	535	847	1353	2151
2	66	106	169	268	424	677	1076
3	44	70	112	178	282	451	717
4	33	53	84	134	212	338	538
5	27	42	67	107	169	271	430
6	22	35	56	89	141	226	359
7	19	30	48	76	121	193	307
8	17	26	42	67	106	169	269
9	15	23	37	59	94	150	239
10	13	21	34	54	85	135	215

### NOTES

- 1) The DMC-101 terminal strip will not accept wire sizes larger than 14 AWG. Use a short run of 14 AWG from the DMC-101 to an auxiliary terminal block when larger wire is needed.
- 2) If the motor is located some distance from the DMC-101, add this length to the overall wire length; be sure to use an appropriate wire size to the motor.
- 3) When multiple actuators are powered by a common set of wires, use the sum of all the motor currents when determining wire size.