

# ▲ PEAKTRONICS

## LRC-101

### Log Rate Controller

The Peaktronics LRC-101 AC Motor Controllers are designed for electric actuators used in continuous modulating applications. An external command signal of 0-10V, 1-5V, or 4-20mA can be used to compare to a feedback signal from a potentiometer. The LRC Series controllers can extend actuator life by averaging rapidly changing input signals, thus reducing unnecessary hunting for position.

The LRC-101 controllers have all of the features of the AMC Series controllers, and is 100% compatible with existing AMC controller installations. The LRC-101 controllers are available in versions for 117VAC  $\pm 10\%$ , 234VAC  $\pm 10\%$ , or 24VAC  $\pm 10\%$  power and give the user optical isolation between the input signal and the AC outputs. The unit includes a red LED indicator (for the *open* output), a green LED indicator (for the *closed* output), an on-board fuse, and two removable screw terminal strips (for easy servicing).

With a loss of command signal in the 1-5V or the 4-20mA input range, the LRC-101 controller offers three useful options: fail in place, the *open* output on, or the *closed* output on. All input and output options are easily field configurable with jumper plugs. The only other adjustments consist of Deadband, non-interactive Zero and Span trimmers, and a "quick-cal" jumper.

The LRC-101A (117VAC), LRC-101B (234VAC), and LRC-101C (24VAC) provide an averaging time of approximately 2 minutes. The LRC-101G (117VAC), LRC-101H (234VAC), and LRC-101I (24VAC) provide an averaging time of approximately 75 seconds, while the LRC-101D (117VAC), LRC-101E (234VAC),

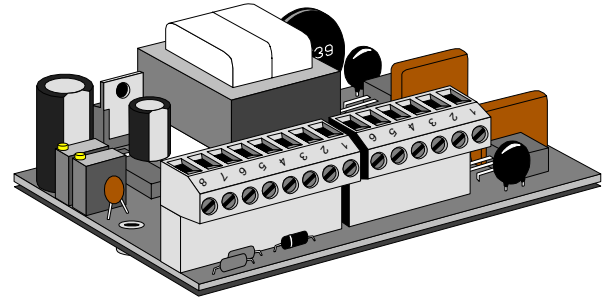

LRC-101A  
LRC-101B  
LRC-101C

LRC-101D  
LRC-101E  
LRC-101F

LRC-101G  
LRC-101H  
LRC-101I

and LRC-101F (24VAC) provide an averaging time of approximately 30 seconds. All nine versions come with standoff mounts (an insulating sheet is included); this allows the units to be mounted directly to the actuator housing or bracket. When properly mounted to the housing or bracket, the LRC-101 controllers can deliver up to 5A at 60°C.

## ADDITIONAL FEATURES

- Logarithmically approaches position by continuously varying duty cycle - no adjustments are required.
- Works with all actuator cycle times, eliminating the need for cycle timer controllers that are used with faster actuators.
- Extends actuator process time, approximately: 2 minutes for the LRC-101A, B, and C, 75 seconds for the LRC-101G, H, and I, and 30 seconds for the LRC-101D, E, and F.
- Finer resolution obtained as a result of log rate pulsing technique.
- Allows actuator to stop before reversing direction.
- Reduces water hammer in critical piping applications.

# OUTLINE

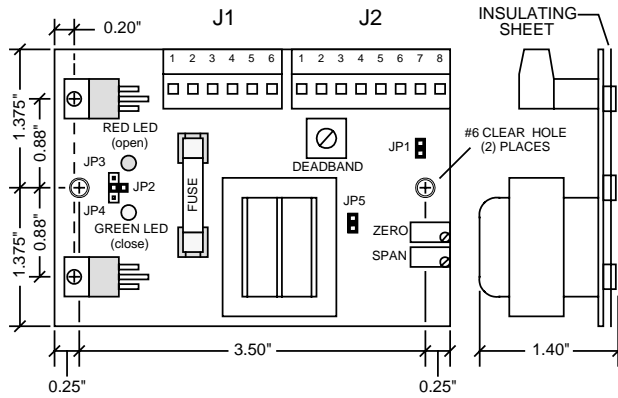

appr. 2 minute Process Time

LRC-101A	117VAC
LRC-101B	234VAC
LRC-101C	24VAC

appr. 30 second Process Time

LRC-101D	117VAC
LRC-101E	234VAC
LRC-101F	24VAC

appr. 75 second Process Time

LRC-101G	117VAC
LRC-101H	234VAC
LRC-101I	24VAC

## ELECTRICAL CONNECTIONS

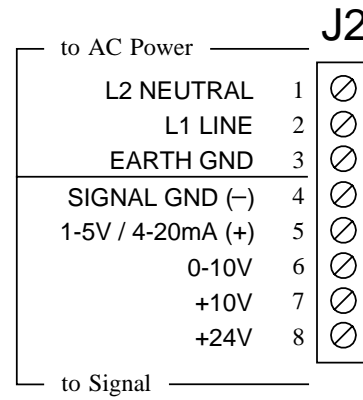
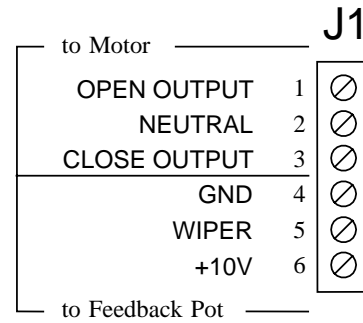

INPUT SIGNAL	
INPUT SIGNAL RANGE	JP1 JUMPER PLUG
0-10V	INSTALL
1-5V	REMOVE
4-20mA	INSTALL

LOSS OF INPUT SIGNAL	
OUTPUT STATE	JUMPER PLUG
BOTH OFF	JP2
OPEN ON	JP3
CLOSE ON	JP4

NOTE: Do not install JP2, JP3, or JP4 when using the 0-10V input signal range. Power must be off when installing these jumpers.

CALIBRATION JP5 JUMPER PLUG	
CALIBRATE	REMOVE
RUN	INSTALL

## BLOCK DIAGRAM

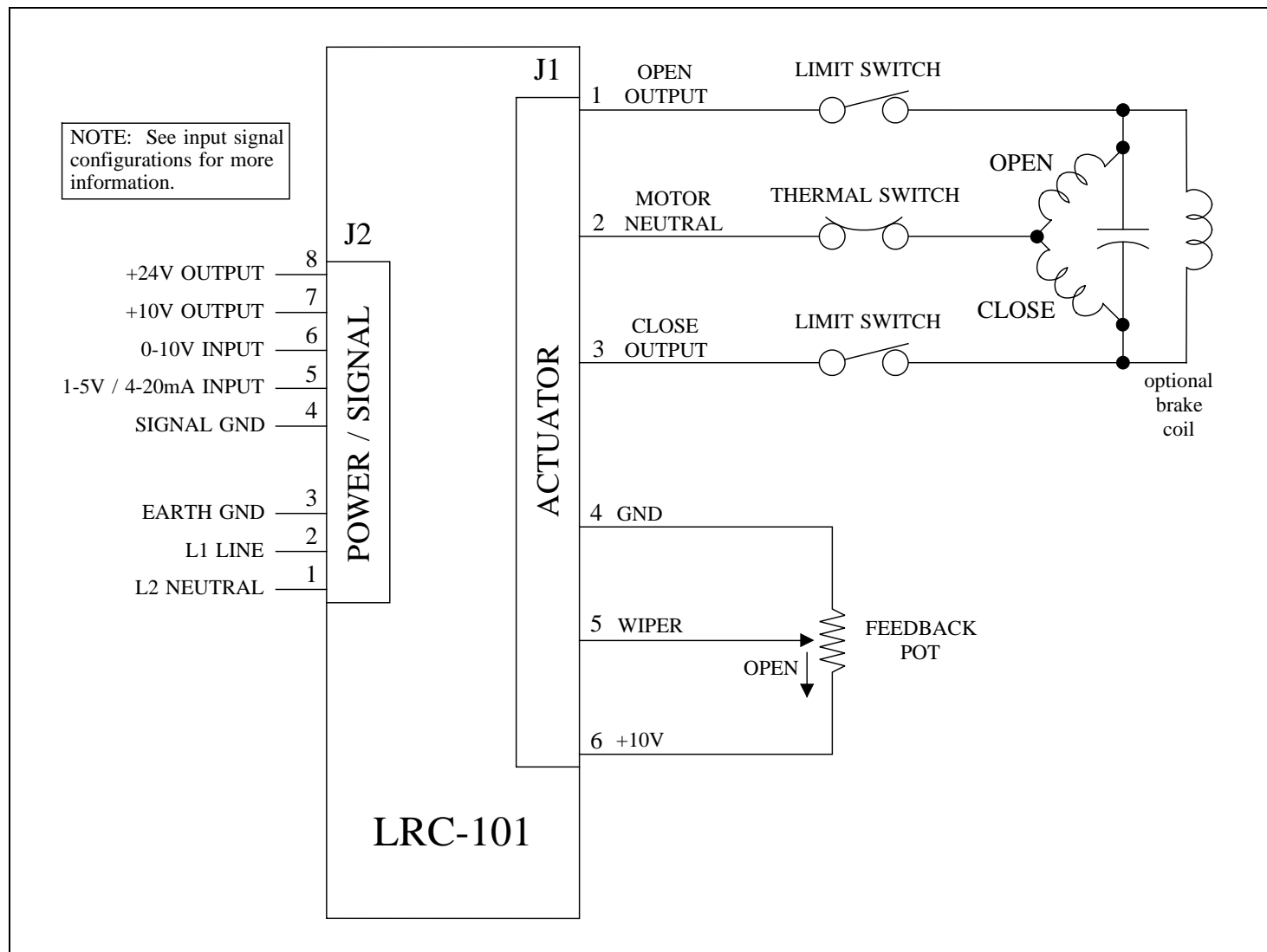

## DESCRIPTION

The LRC-101 AC Motor Controllers come in various configurations to accommodate many applications. Basically two parameters should be considered in selecting the appropriate model: operating voltage, and process time (see Outline information).

The LRC-101 controllers are rated for 5A motors and are available for either 117VAC, 234VAC, or 24VAC operation. The units are available in either a 30 second process time, a 75 second process time, or a 2 minute process time.

All models have standoffs for direct mounting to a bracket (insulating sheet is included). The unit requires screw mounting through all four standoffs to a suitable metal plate or bracket in order to provide sufficient heat-sinking for the unit.

## INSTALLATION

**SHOCK HAZARD!** These units are intended to be mounted in an appropriate enclosure connected to earth ground through wiring or piping. High voltages are present on the outside of the unit when power is applied. The power source should be disconnected prior to any wiring of these units to avoid an electrical shock.

**OUTDOOR CONSIDERATION!** A heater and thermostat should be used where low temperatures and/or condensation may occur. Installing a clay based desiccant packet at the time of final access prior to sealing the cover is highly recommended. This will reduce the dew and frost points by reducing the relative humidity inside the actuator.

## POWER / SIGNAL (J2)

Power is connected to pins 1, 2, and 3 as shown in the Block Diagram. The fuse installed on the unit is rated for maximum output current that can be safely delivered by the AC outputs. Replacement fuses must not exceed the maximum rating of 6.3A in order to prevent damage to the unit. Smaller fuse sizes can be used with smaller motors - consult the actuator manufacturer for appropriate fuse size and type.

An appropriate command signal, either 0-10V, 1-5V, or 4-20mA, should be connected to pin 5 or 6 (as shown in the Block Diagram) while using pin 4 as the return *signal ground*. The LRC-101 must be configured for the type of command signal that is to be used - jumper plug JP1 must be installed whenever a 4-20mA or 0-10V input is used (see Outline).

Pin 7 of J2 provides an auxiliary +10V output which can be used to connect a command potentiometer. By connecting one end of a potentiometer to pin 7, the other end to pin 4, and the wiper to pin 6, a local control knob can be implemented. Pin 8 provides an auxiliary +24VDC output which can be used to power an input or output 4-20mA transmitter.

## ACTUATOR (J1)

The actuator and feedback potentiometer are connected to J1 as shown in the block diagram. Pin 1 should be connected to the motor winding that moves the actuator toward the *open* position, and conversely, pin 3 is connected to the winding that moves the actuator toward the *closed* position. Pin 2 is the neutral or common wire to the motor windings. The LRC-101 is suitable for powering most dynamic brakes used with electric actuators; however, consult the actuator manufacturer for more information.

The feedback potentiometer wiper must be connected to pin 5 of J1. One end of the potentiometer is connected to pin 4, and the other is connected to pin 6. The potentiometer should be connected so that when the actuator moves towards the *open* position, the potentiometer's resistance between pins 4 and 5 will increase. This can also be measured as a voltage - the voltage between pins 4 and 5 should increase when the actuator moves towards the *open* position. If the potentiometer is wired incorrectly, the typical response of the unit will be to run the actuator to the full open or closed position (the appropriate output indicator will remain on) regardless of the command signal input.

The feedback potentiometer should be mounted to provide a proper feedback signal through the entire range between the *open* and *closed* positions. For best results,

position the actuator to the midway point between the *open* and *closed* positions; then adjust the feedback potentiometer for approximately 5VDC (or 1/2 of the potentiometer's resistance) between pins 4 and 5 of J1.

Since the feedback potentiometer is crucial for proper operation of the LRC-101, the following items should be carefully observed:

- 1 - Potentiometer resistance should be a value from 1K to 10K ohms.
- 2 - The potentiometer should be a linear taper type.
- 3 - The potentiometer must be properly wired to provide the correct feedback signal.
- 4 - The potentiometer must be properly and securely mounted in order to provide a reliable feedback signal.

## OUTPUT INDICATORS

The LRC-101 units have on-board indicators that identify when one of the motor outputs is turned on. When the open output is turned on, the red LED indicator will turn on, and when the close output is turned on the green LED indicator will turn on (see Outline).

Many actuators are equipped with limit switches at the *open* and *closed* positions which are intended to disconnect power to the motor to prevent mechanical damage. For this reason, it is possible that the LRC-101 will indicate that one of the motor outputs is turned on when the actuator is not in motion. However, it should be noted that when the indicator is on, power is applied to the motor output.

## LOSS OF INPUT SIGNAL

When the 1-5V or 4-20mA type command signal is used, the LRC-101 can detect that the input signal has been disconnected. The unit can be configured to respond to the loss of command signal in one of three ways: turn both outputs off (leaving the actuator in its last position at the time signal was lost), turn on the open output (to move the actuator to the full *open* position), or turn on the close output (to move the actuator to the full *closed* position). To select the desired response to a loss of input signal, install jumper plug JP2, JP3, or JP4 as shown in the Outline information. **CAUTION!** Power must be disconnected when installing or removing these jumpers - damage to the unit may occur if these jumpers are set with power on.

When using this feature, certain precautions should be observed. For applications using the 0-10V input signal type, the unit **cannot** detect a loss of signal; **do not** install jumper plugs JP2, JP3, and JP4 for these applications. When JP3 or JP4 are installed, the unit will turn on one of the motor outputs when the input signal is lost, and the actuator will run at full speed, rather than pulsing, to the end of travel. If the actuator does not use limit switches, these selections should not be used.

## CALIBRATION

The non-interactive zero and span adjustments along with the "quick-cal" jumper of the LRC-101 allow for easy calibration once the unit is installed. After insuring that the feedback potentiometer and motor outputs are wired to provide a proper feedback signal, as described under "ACTUATOR (J1)", follow these steps to calibrate the unit (see Outline for the location of the adjustments):

- 1 - Remove the "quick-cal" jumper (JP5).
- 2 - Apply AC power to the unit, and set the command input signal to minimum:

0V for 0-10V input type  
 1V for 1-5V input type  
 4mA for 4-20mA input type

- 3 - Adjust the "Zero" adjustment so that the actuator moves to the desired *closed* position. If the desired position cannot be achieved, check that the feedback potentiometer provides a feedback signal as described under "ACTUATOR (J1)"; also, check the position of the limit switches.
- 4 - If the actuator is hunting for position, turn the "Deadband" adjustment clockwise until hunting stops. If the actuator is not hunting for position, turn the "Deadband" adjustment counterclockwise until the actuator begins to hunt; then turn the "Deadband" adjustment slightly clockwise until hunting stops.

**WARNING!** Actuator failure may occur if the "Deadband" adjustment is set to allow continuous hunting. This can cause excessive wear of motor bearings, geartrain, dynamic brake, and feedback potentiometer. Hunting can also cause the internal temperature of the actuator housing to rise to a level that exceeds the maximum rating of the LRC-101, 60°C.

- 5 - Set the command signal input to maximum:

10V for 0-10V input type  
 5V for 1-5V input type  
 20mA for 4-20mA type

- 6 - Adjust the "Span" adjustment so that the actuator moves to the desired *open* position. If the desired position cannot be achieved, check the position of the limit switch.

**NOTE:** The "Zero" adjustment is an offset setting rather than an absolute setting. Should the "Zero" adjustment be changed, the "Span" adjustment should be checked for the desired *open* position. Setting of the "Span" adjustment has no affect on the "Zero" adjustment.

- 7 - To check proper operation and linearity, set the command signal to halfway:

5V for 0-10V input type  
 3V for 1-5V input type  
 12mA for 4-20mA input type

Verify that the actuator's position is midway between the *open* and *closed* positions.

- 8 - Install the "quick-cal" jumper (JP5). Note that after installing JP5, the actuator will take approximately 30 seconds, 75 seconds, or 2 minutes depending on the model, to move to the desired position. This also occurs on power up.

## REVERSE ACTING CALIBRATION

When converting a direct acting actuator to a reverse acting actuator, two changes in wiring must be made:

- 1 - Reverse the feedback potentiometer wires connected to J1-4 and J1-6.
- 2 - Reverse the motor output wires connected to J1-1 and J1-3.

**NOTE: DO NOT** reverse the input signal polarity. Also, make sure that both wiring changes are made - if only one is made, the actuator will run to either full *open* or full *closed*.

After the wiring changes have been made, refer to **CALIBRATION** for setting the zero and span adjustments.

## SPECIFICATIONS

### POWER REQUIREMENTS

LRC-101A, LRC-101D, LRC-101G: 117VAC  $\pm$ 10%, 50/60 Hz

LRC-101B, LRC-101E, LRC-101H: 234VAC  $\pm$ 10%, 50/60 Hz

LRC-101C, LRC-101F, LRC-101I: 24VAC  $\pm$ 10%, 50/60 Hz

3.6 VA typical (not including output load)

Fuse Type: 6.3A 3AG Time Delay

### PROCESS TIME

LRC-101A, LRC-101B, LRC-101C: appr. 2 minutes

LRC-101D, LRC-101E, LRC-101F: appr. 30 seconds

LRC-101G, LRC-101H, LRC-101I: appr. 75 seconds

### COMMAND SIGNAL INPUT

0-10 VDC Input

Input Impedance: 11K ohms minimum

External Command Potentiometer: 1K ohm

1-5 VDC Input

Input Impedance: 1M ohms minimum

*Loss of Command Signal* Threshold:  $\leq$  0.75V

4-20 mA Input

Input Impedance: 250 ohms  $\pm$ 1%

*Loss of Command Signal* Threshold:  $\leq$  3mA

### FEEDBACK SIGNAL INPUT

Input Voltage: 0 to 10 VDC

External Feedback Potentiometer: 1K ohm to 10K ohms

### POWER SUPPLY OUTPUTS

Input or Output Transmitter Power (J2-8): 24VDC @ 20mA max

Command Signal Potentiometer Power (J2-7): 10VDC @ 10mA max

**NOTE:** *Do not* connect these outputs to other power supplies.

### AC MOTOR OUTPUTS

Off-state Leakage Current: <15mA

Maximum Load Current @ 60°C: 5A (when properly mounted)

### CONTROL ADJUSTMENTS

Zero: adjustable throughout feedback signal range

Span: adjustable throughout command signal range

Deadband: adjustable from 0.12% to 2.4% of span

### ENVIRONMENTAL

Operating Temperature Range: 0 °C to 60 °C

Storage Temperature Range: -40 °C to 85 °C

Relative Humidity Range: 0 to 90 % (noncondensing)

## WIRING DIAGRAMS

### Input Signal Configurations

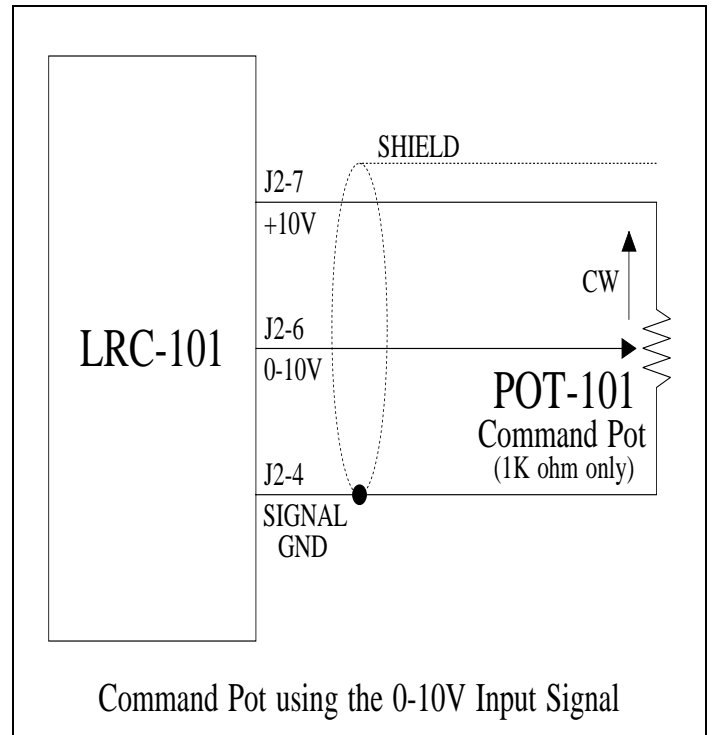
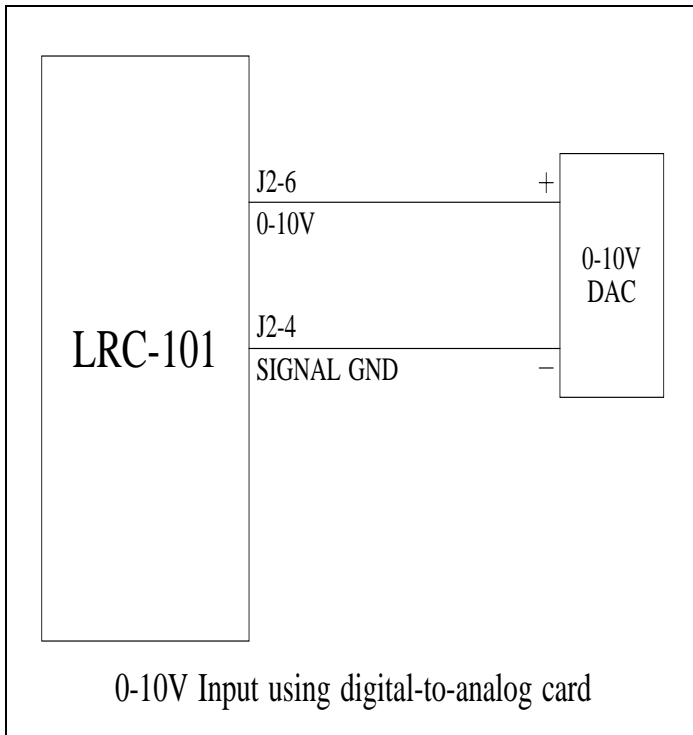
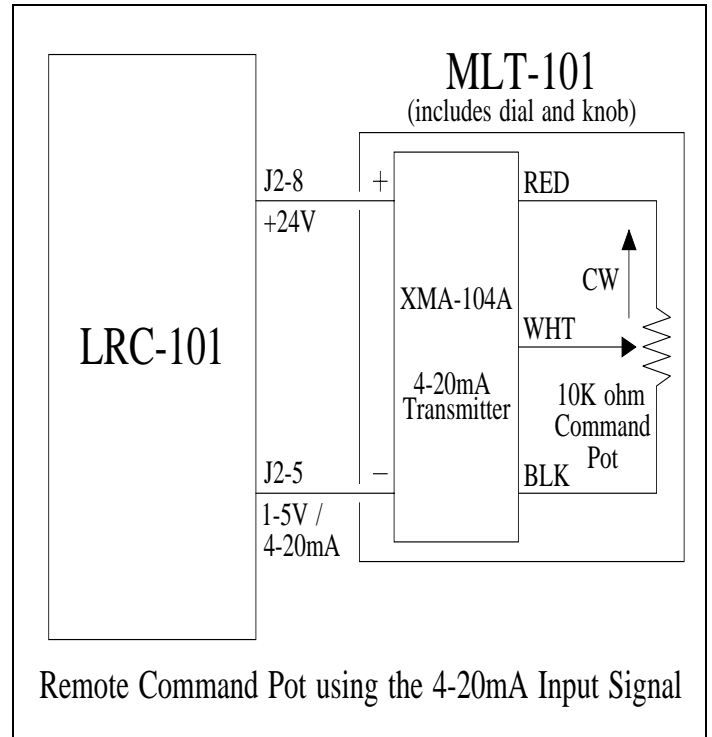
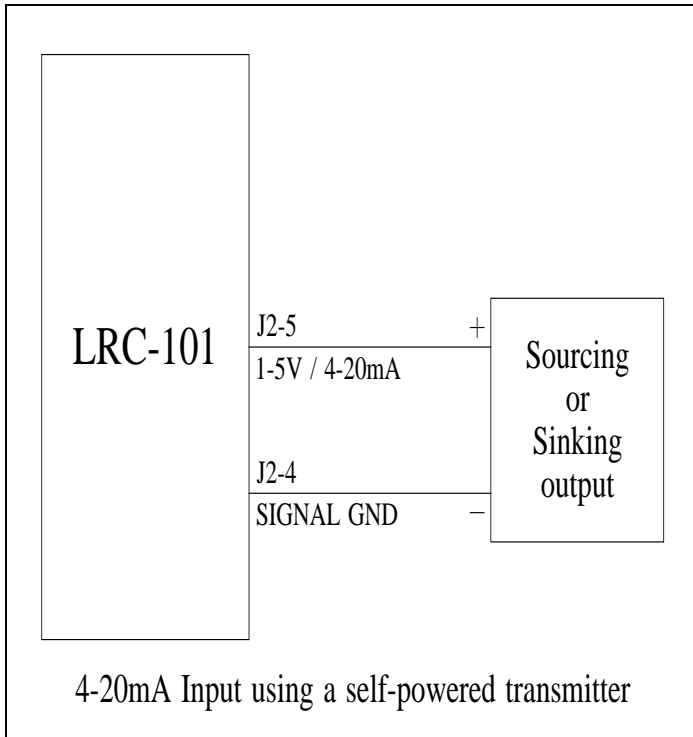

## WIRING DIAGRAMS

### Special Applications

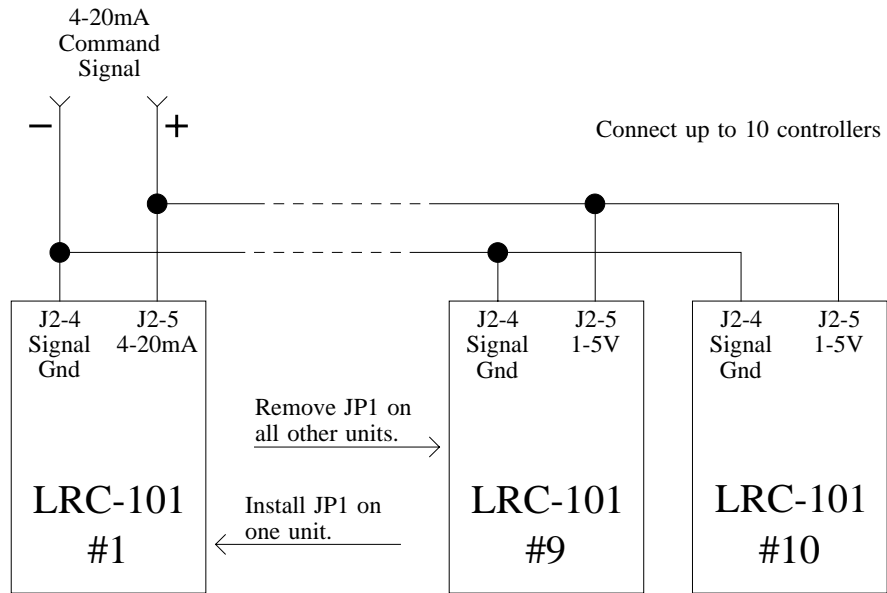

Controlling multiple units using a single 4-20mA signal

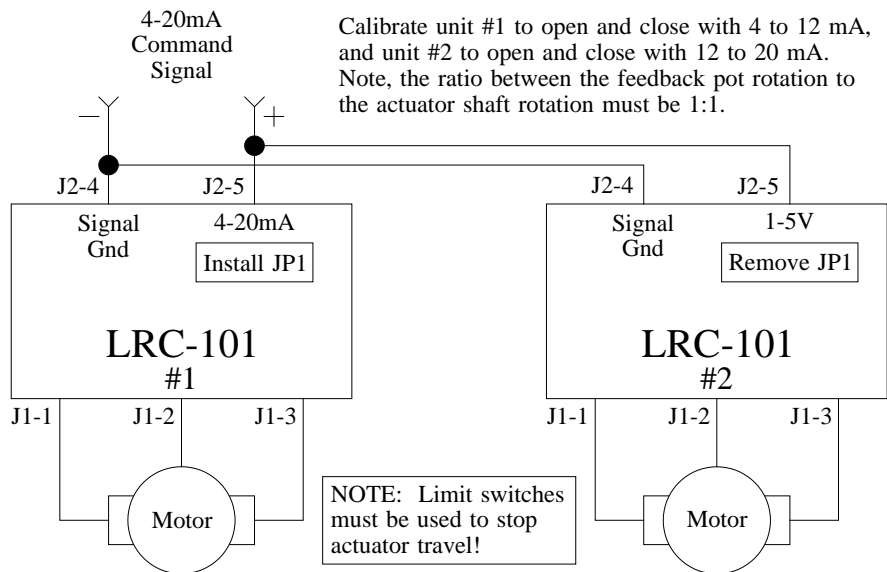

Split range control