

▲ PEAKTRONICS

The Peaktronics AMI-100 / AMI-101 AC Motor Interfaces are used to interface common electrical control signals to AC actuators. The unit provides the motor drive circuits, protection circuits, and isolation between the control inputs and motor outputs. A wide range of external control signals can be used to Open and Close the actuator. The unit accepts commonly used 120VAC signals from PLC modules, relay circuits, triac outputs, or solid state relay circuits. Alternatively, signals from a number of electronic sources, including TTL, CMOS, analog drivers, and low voltage AC outputs, can be used.

The unit has a built-in repeat cycle timer that can be independently enabled or disabled for Open and Close. The timer can be adjusted for 0.1 to 2 seconds "ON" time and for 0.5 to 10 seconds "OFF" time. Since some AC motors cannot be switched instantly from open to close operation, the unit provides an adjustable input delay feature.

The unit also features a red LED indicator (for the *open* output), a green LED indicator (for the *closed* output), an on-board fuse, two removable screw terminal strips (for easy servicing), on-board switches to manually open or close the actuator, and an auxiliary +24VDC power output that can be used to power a 4-20mA or 0-5/10V transmitter. A transmitter (such as the Peaktronics XMA-105 or XMA-106) can be used to provide a position feedback signal from a feedback potentiometer (such as the Peaktronics POT-102).

The units are available in two different current ranges (2A at 60°C or 5A at 60°C) with three different mounting styles. Standoff mount units include an insulating sheet and allow the units to be mounted directly to the actuator housing or bracket. Note, 5A Standoff Mount units must be mounted to the actuator housing or bracket for proper heatsinking.

AMI-100 AMI-101

AC Motor Interface

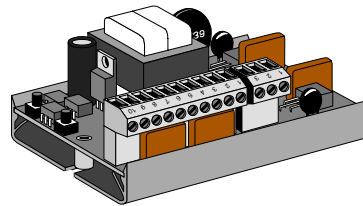

AMI-100
AMI-100B
AMI-100D

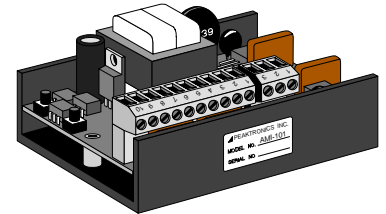

AMI-101
AMI-101B
AMI-101D

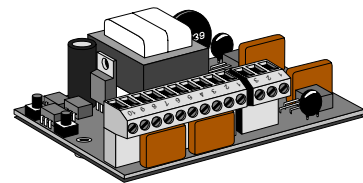

AMI-100A
AMI-100C
AMI-100E
AMI-101A
AMI-101C
AMI-101E

2A Motor Output

117 VAC ±10%
234 VAC ±10%
24 VAC ±10%

Snaptrack® Mount

AMI-100
AMI-100B
AMI-100D

Standoff Mount

AMI-100A
AMI-100C
AMI-100E

5A Motor Output

117 VAC ±10%
234 VAC ±10%
24 VAC ±10%

Extrusion Mount

AMI-101
AMI-101B
AMI-101D

Standoff Mount

AMI-101A
AMI-101C
AMI-101E

OUTLINE

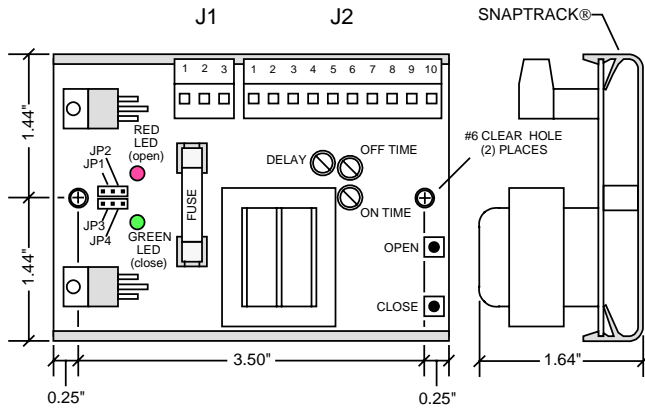

AMI-100 117VAC, 2A
 AMI-100B 234VAC, 2A
 AMI-100D 24VAC, 2A

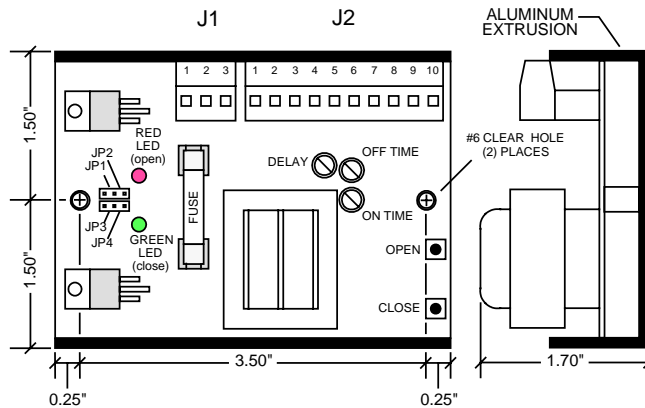

AMI-101 117VAC, 5A
 AMI-101B 234VAC, 5A
 AMI-101D 24VAC, 5A

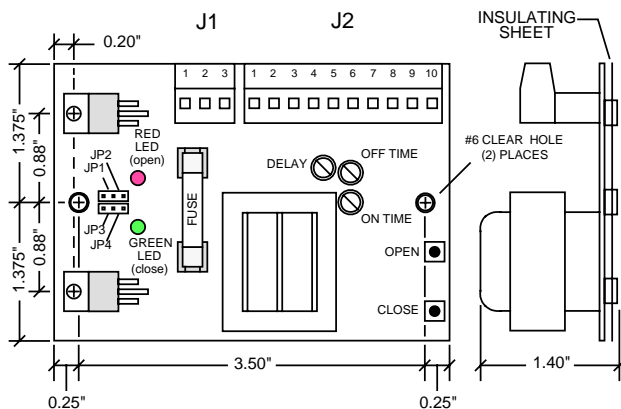

AMI-100A 117VAC, 2A AMI-101A 117VAC, 5A
 AMI-100C 234VAC, 2A AMI-101C 234VAC, 5A
 AMI-100E 24VAC, 2A AMI-101E 24VAC, 5A

ELECTRICAL CONNECTIONS

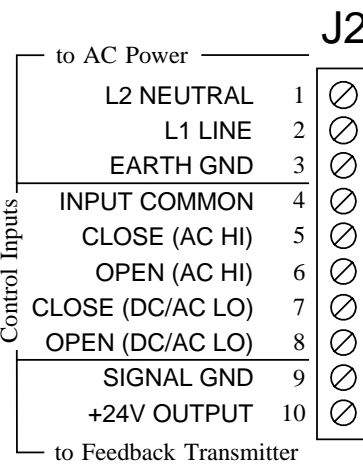
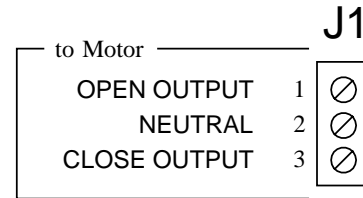

NOTE: Control Input connections are isolated from the Feedback Transmitter connections.

OPEN TIMER	JUMPER PLUG
ENABLED	JP1
DISABLED	JP2

CLOSE TIMER	JUMPER PLUG
ENABLED	JP3
DISABLED	JP4

NOTE: The open output will be disabled if neither JP1 or JP2 is installed. Likewise, the close output is disabled if neither JP3 or JP4 is installed.

BLOCK DIAGRAM

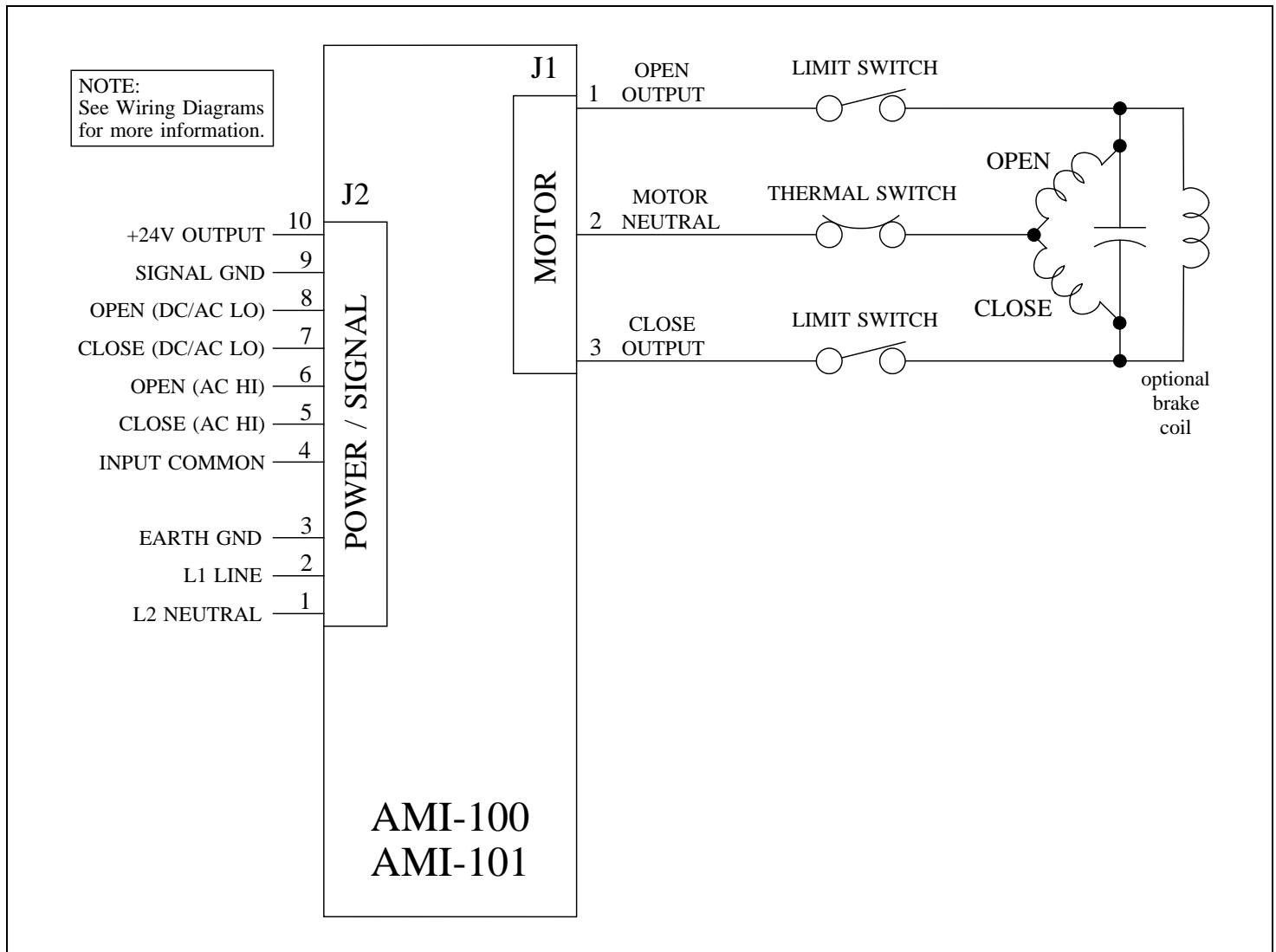

DESCRIPTION

The AMI-100/AMI-101 AC Motor Interfaces come in various configurations to accommodate many applications. Basically three parameters should be considered in selecting the appropriate model: motor current, operating voltage, and package configuration (see Outline information).

The AMI-100 units are rated for 2A motors and are available for either 117VAC, 234VAC, or 24VAC operation. The AMI-100, AMI-100B, and AMI-100D come mounted on snaptrack while the AMI-100A, AMI-100C, and AMI-100E have standoffs for direct mounting to a bracket (insulating sheet is included).

The AMI-101 units are rated for 5A motors and also come in 117VAC, 234VAC, or 24VAC versions.

The AMI-101, AMI-101B, and AMI-101D are packaged on an aluminum extrusion. The AMI-101A, AMI-101C, and AMI-101E come with standoff mounts - these units **require** screw mounting through all four standoffs to a suitable metal plate or bracket in order to provide sufficient heatsinking for the unit.

CAUTION ! These units are intended to be mounted in an appropriate enclosure to avoid electrical shocks. High voltages are present on the outside of the unit when power is applied. AC power should be disconnected prior to any wiring of these units. A heater and thermostat should be used where condensation may occur.

POWER / SIGNAL (J2)

Power is connected to pins 1, 2, and 3 as shown in the Block Diagram. The fuse installed on the unit is rated for maximum output current that can be safely delivered by the AC outputs. To prevent damage to the unit, replacement fuses must not exceed these maximum ratings (2A for the AMI-100 units and 5A for the AMI-101 units). Smaller fuse sizes can be used with smaller motors - consult the actuator manufacturer for appropriate fuse size and type.

The control signal to open the actuator is connected to either pin 6 or pin 8 (**do not** connect both inputs at the same time), while the close control signal is connected to either pin 5 or pin 7 (**do not** connect both at the same time). Both open and close inputs use INPUT COMMON (pin 4) as the return. The AC HI inputs (pins 5 and 6) are suitable for 120VAC control signals, while the DC/AC LO inputs are used for either DC electronic signals (such as TTL, CMOS, etc.) or AC control signals up to 90VAC.

Pin 10 of J2 provides an auxiliary +24VDC output which can be used to power an output transmitter. SIGNAL GND (pin 9) is used as the return line for the transmitter. SIGNAL GND (pin 9) and INPUT COMMON (pin 4) are both isolated from the motor outputs on J1 and are isolated from each other. Pin 4 and 9 **should not** be connected together when using control signals that are not isolated from the AC power line (pins 1, 2, and 3).

MOTOR (J1)

Pin 1 should be connected to the motor winding that moves the actuator toward the *open* position, and conversely, pin 3 is connected to the winding that moves the actuator toward the *closed* position. Pin 2 is the neutral or common wire to the motor windings. The AMI-100/AMI-101 is suitable for powering most dynamic brakes used with electric actuators; however, consult the actuator manufacturer for more information.

OUTPUT INDICATORS

The AMI-100/AMI-101 units have on-board indicators that identify when one of the motor outputs is turned on. When the open output is turned on, the red LED indicator will turn on, and when the close output is turned on the green LED indicator will turn on (see Outline).

Many actuators are equipped with limit switches at the *open* and *closed* positions which are intended to disconnect power to the motor to prevent mechanical dam-

age. For this reason, it is possible that the AMI-100/AMI-101 will indicate that one of the motor outputs is turned on when the actuator is not in motion. However, it should be noted that when the indicator is on, power is applied to the motor output.

INPUT DELAY

Since some AC motors do not operate correctly when power is instantaneously switched between the Open and Close windings, the AMI-100/AMI-101 provides an input delay. If one output is on and the control signal inputs are switched to reverse the motor, the unit will delay turning on the other output. This delay is adjustable; see Specifications under "Control Adjustments" for delay period and Outline for location of the adjustment. When both outputs are off and a control input signal is applied, the Input Delay setting causes a delay in turning on the associated output. If the control signal is removed before the end of the delay period, the associated output will not turn on.

OPEN and CLOSE SWITCHES

The AMI-100/AMI-101 provides on-board switches that allow manual operation from the unit - see Outline for location of the switches. Pressing the *open* switch will turn on the Open output (J1 pin 1), while pressing the *close* switch turns on the Close output (J1 pin 3). Since the OPEN and CLOSE switches replace the control signal inputs, the Input Delay function effects the switch operation in the same manner as a control signal - refer to INPUT DELAY for more details.

To protect against turning on both outputs at the same time, the AMI-100/AMI-101 will not turn on one of the outputs until the other output has turned off. Additionally, if both control signals are applied at the same time, the unit will turn off both outputs. This is true of any combination of control signals or on-board switch operation. For example, if a PLC is applying a control signal to the CLOSE input while someone is pressing the *open* switch, both outputs will be turned off.

REPEAT CYCLE TIMER

The AMI-100/AMI-101 has a built-in repeat cycle timer that can be used to adjust the actuator speed. The timer automatically cycles the output on and off whenever the associated control input is applied. The ON time is adjustable from 0.1 to 2 seconds, while the OFF time is adjustable from 0.5 to 10 seconds. The timer function can be enabled or disabled for each output independently by installing jumpers for the desired operation. See Outline for location of adjustments and jumpers.

SPECIFICATIONS

POWER REQUIREMENTS

AMI-100, AMI-100A, AMI-101, AMI-101A: 117VAC $\pm 10\%$, 50/60 Hz
AMI-100B, AMI-100C, AMI-101B, AMI-101C: 234VAC $\pm 10\%$, 50/60 Hz
AMI-100D, AMI-100E, AMI-101D, AMI-101E: 24VAC $\pm 10\%$, 50/60 Hz
3.6 VA typical (not including output load)
Fuse Type:
AMI-100x: 2A 3AG Slo-Blo
AMI-101x: 5A 3AG Slo-Blo

AC HI CONTROL SIGNAL INPUTS

Maximum Input Voltage: 130VAC 50/60 Hz (20 mA typical @ 60 Hz)
Minimum ON Voltage: 85VAC 50/60 Hz (13 mA typical @ 60 Hz)
Maximum OFF Voltage: 60VAC 50/60 Hz (8.8 mA typical @ 60 Hz)
Maximum OFF State Input Current: 7.5 mA @ 60 Hz / 6 mA @ 50 Hz

DC/AC LO CONTROL SIGNAL INPUTS

Maximum Input Voltage:
130VDC (4 mA typical)
90VAC 50/60 Hz (3.3 mA typical)
Minimum ON Voltage:
2.4VDC (0.4 mA maximum), TTL compatible
1.9VAC (0.16 mA typical)
Maximum OFF Voltage:
1.8VDC
1.3VAC
Maximum OFF State Input Current: 0.25 mA DC / 0.1 mA AC

+24V OUTPUT

24VDC $\pm 5\%$ @ 30mA max

AC MOTOR OUTPUTS

Off-state Leakage Current: <15mA
Maximum Load Current @ 60°C:
AMI-100x: 2A
AMI-101x: 5A (when properly mounted)

CONTROL ADJUSTMENTS

Cycle Timer, ON Time: 0.1 to 2 seconds
Cycle Timer, OFF Time: 0.5 to 10 seconds
Input Delay:
0.056 to 1.5 second, switching inputs
0.017 to 1 second, single input

ENVIRONMENTAL

Operating Temperature Range: 0 °C to 60 °C
Storage Temperature Range: -40 °C to 85 °C
Relative Humidity Range: 0 to 90 % (noncondensing)

WIRING DIAGRAMS

Input Signal Configurations

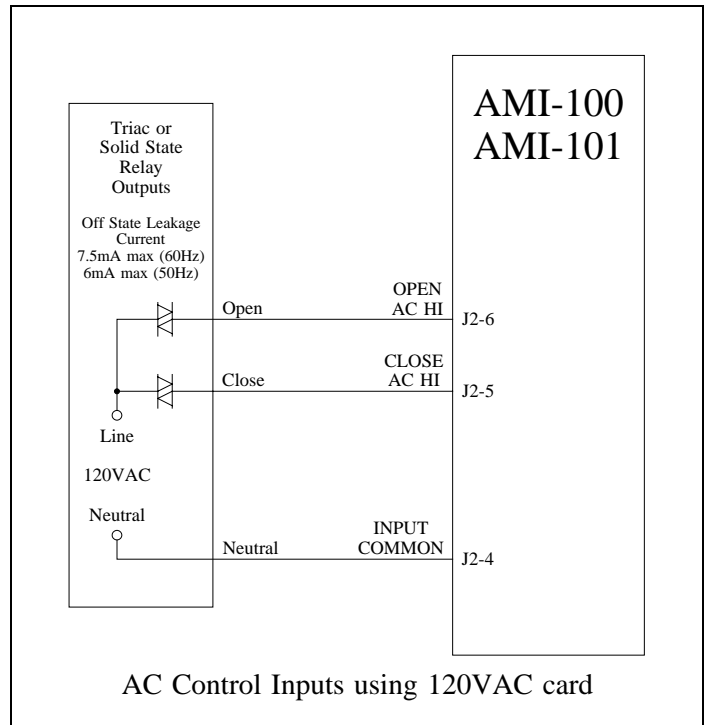
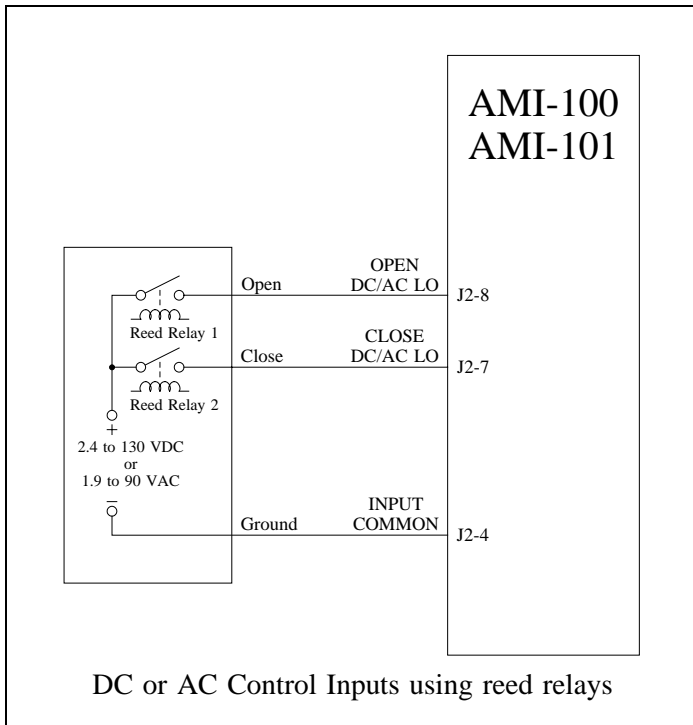
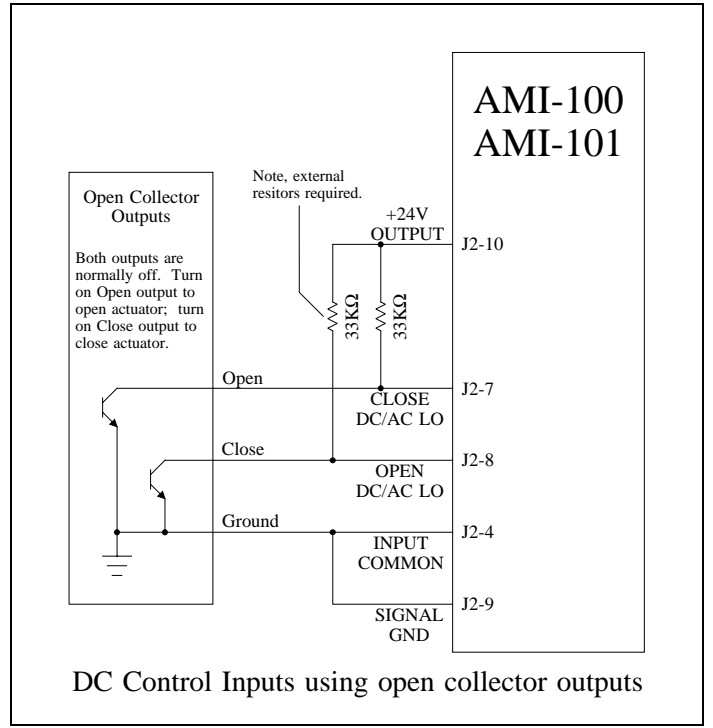
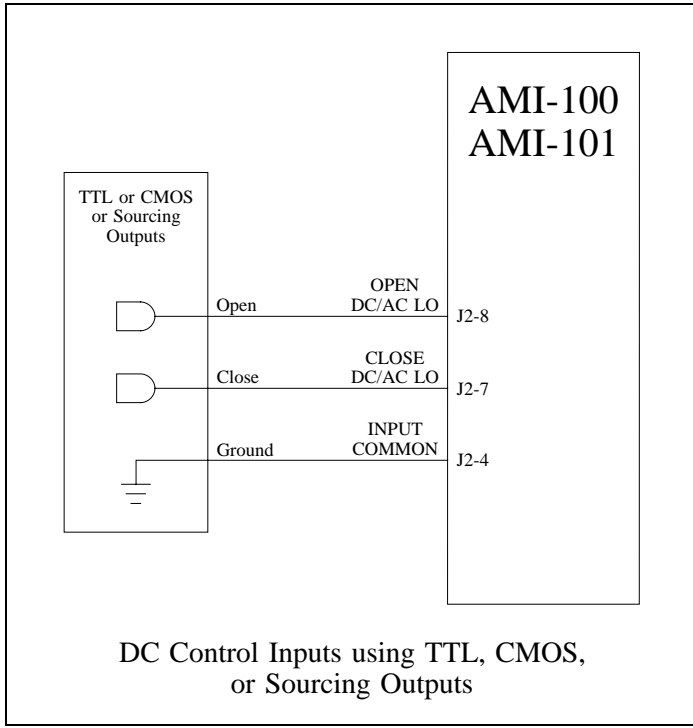

WIRING DIAGRAMS

Input Signal Configurations

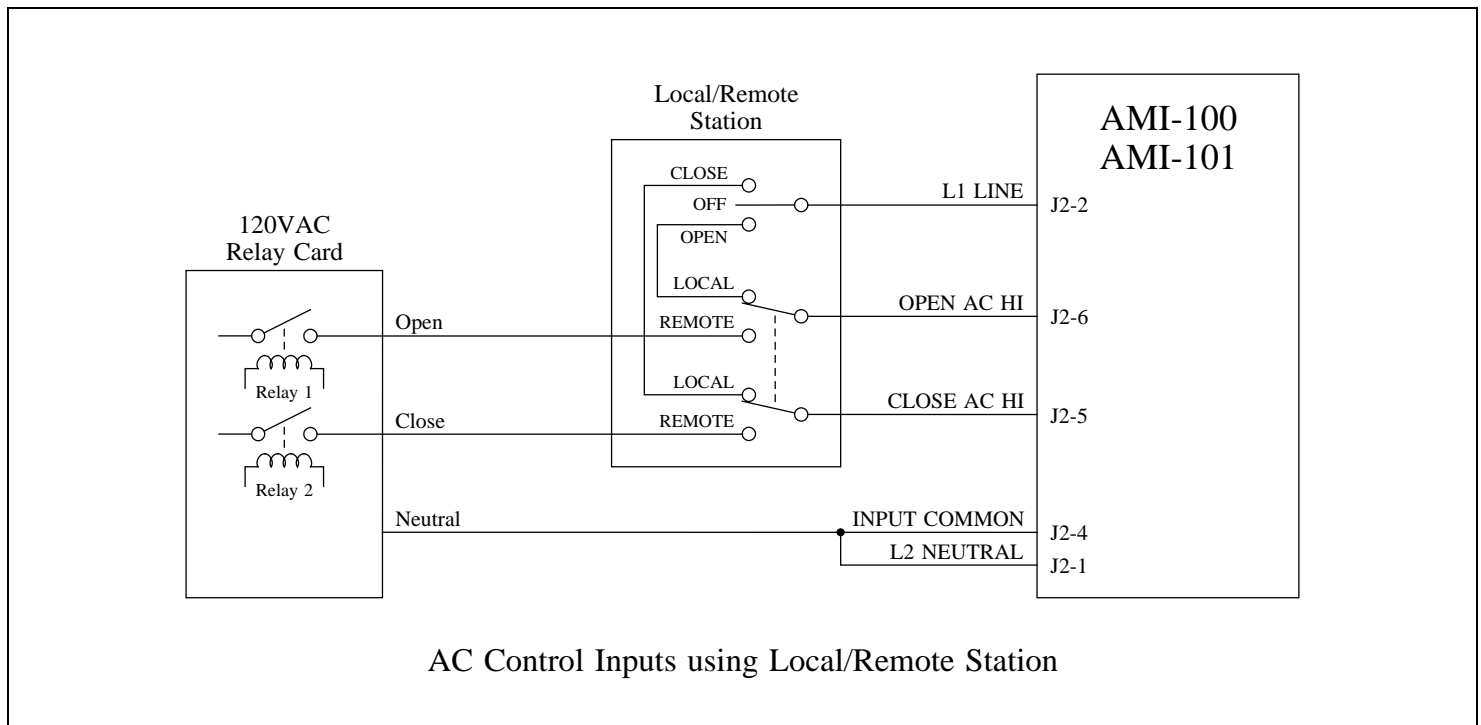
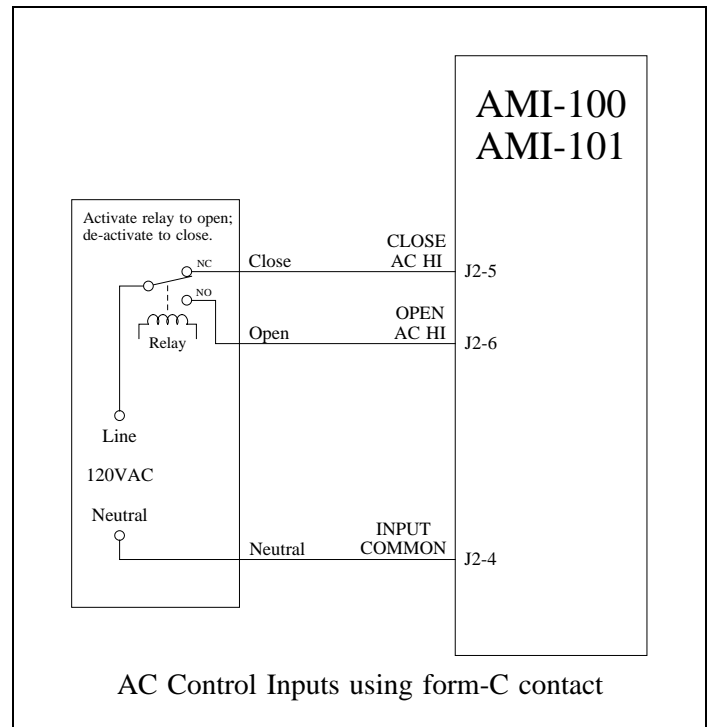
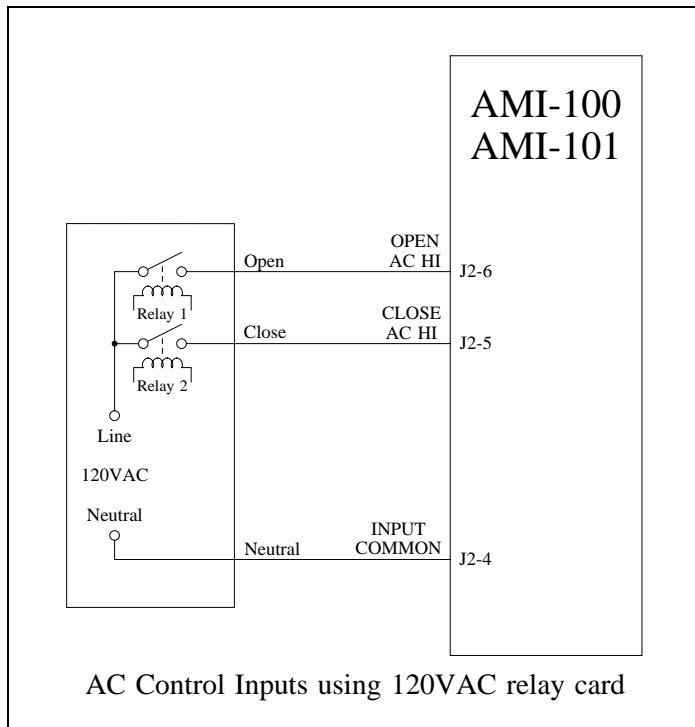

WIRING DIAGRAMS

Feedback Transmitters

