

Quick Calibration Procedure

General

The MODE button selects a particular function, or mode, and the indicator for the selected mode turns on solid. Pushing the MODE button saves any new setting of the current mode before switching to the next mode. The adjust up (▲) and adjust down (▼) buttons are used to make adjustments to current mode. For more details regarding calibration and features refer to the manual.

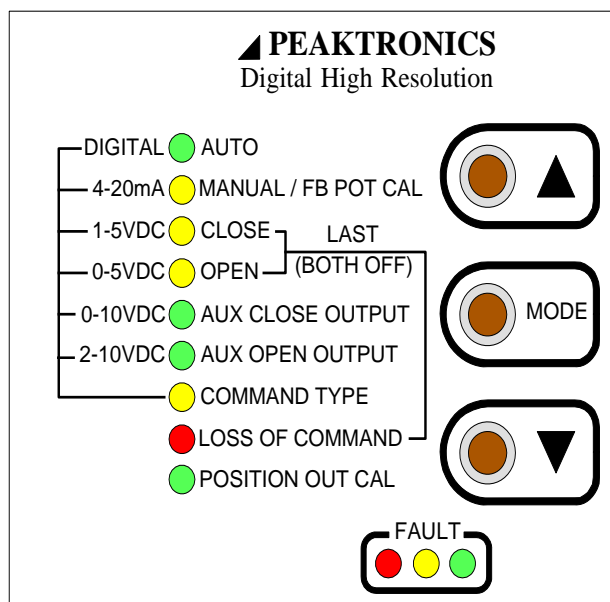

REFERENCE ROTATIONS

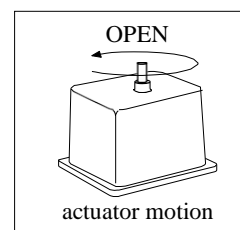

DIRECT ACTING

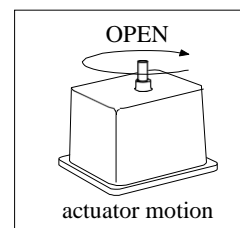

REVERSE ACTING

1. Before applying power, ensure that the unit is properly mounted and properly wired to the actuator. Refer to the pertinent MKT Data Sheet specified for the actuator. Ensure potentiometer gears are tight and properly meshed.
2. Apply power to the actuator on Connector J2: terminal #1 (neutral), terminal #2 (line), and terminal #3 (earth). There is no need for a signal connection during calibration.
3. Push the MODE button until the yellow “MANUAL/FB POT CAL” LED is illuminated. The LED may be flashing (at different speeds) through the next several steps. This is expected and will be explained.
4. Use the adjust buttons (▲ and ▼) to move the actuator and verify that the limit switches are set past the desired open and closed positions, but not so far as to interfere with the mechanical end stops, if the actuator has this feature. Then move the actuator to mid stroke.
5. If LED is solid, proceed to step 7.
6. If LED is flashing, loosen the gear on the actuator shaft and rotate the potentiometer gear until the LED is no longer flashing, but on solid - this indicates the center of the potentiometer’s travel. Note that the LED will flash at a slower rate the farther away from the mid position it gets. Once the LED is on solid tighten the actuator shaft gear and ensure that the gear engagement is tight and properly meshed.
7. Push the MODE button until the “CLOSE” LED is lit solid. Use the adjust buttons (▲ and ▼) to drive the actuator toward the desired closed position until the associated limit switch trips. Then tap the other adjust button to move the actuator just off the limit switch to the desired valve closed position.

Quick Cal & Troubleshooting Guide

8. Push the MODE button until the “OPEN” LED is lit solid. Use the adjust buttons (▲ and ▼) to drive the actuator toward the desired open position until the associated limit switch trips. Then tap the other adjust button to move the actuator just off the limit switch to the desired valve open position.
9. If an OTR-100 or OTR-101 option module is installed, follow **Auxiliary Open/Close Setup** (see below); otherwise continue to the next step.
10. Push the MODE button until the “COMMAND TYPE” LED is lit solid. Use the adjust buttons (▲ and ▼) to select appropriate input signal (4-20mA, 1-5VDC, 0-5VDC, 0-10VDC, 2-10VDC, or Digital). If 0-5VDC or 0-10VDC is selected, the LOSS OF COMMAND feature is not available, so proceed to step 12.
11. Push the MODE button until the “LOSS OF COMMAND” LED is lit solid; this sets the actuator to a predetermined position upon loss of command. Use the adjust buttons (▲ and ▼) to select appropriate position (OPEN, CLOSE, or LAST POSITION).
12. If an OTR-100, OTR-101, OTX-100, or OTX-101 option module is installed, follow **Position Output Mode Setup** (see below); otherwise continue to the next step.
13. Push the MODE button until the “AUTO” LED is lit solid. Your calibration is now **COMPLETE**. Connect the command signal wires to connector J2: terminal #4 (signal ground) and terminal #5 (mA input) **OR** terminal #6 (voltage input), depending on the application. If a signal input was already connected, the actuator should have moved to that position.

Auxiliary Open/Close Setup (for units with an OTR-100 or OTR-101 option module only)

1. Push the MODE button until the “AUX CLOSE OUTPUT” LED is lit solid. Use the adjust buttons (▲ and ▼) to drive the actuator to the desired auxiliary close position.
2. Push the MODE button until the “AUX OPEN OUTPUT” LED is lit solid. Use the adjust buttons (▲ and ▼) to drive the actuator to the desired auxiliary open position.
3. Continue with Step 10 in the **Quick Calibration Procedure** (see above).

Position Output Mode Setup (for units with an OTR-100, OTR-101, OTX-100, or OTX-101 option module only)

1. Push the MODE button until the green “POSITION OUT CAL” LED is lit solid **while** the “CLOSE” LED flashes.
2. Use the adjust buttons (▲ and ▼) to set the desired output voltage (VDC) or current (mA) on the option module output for the closed position.
3. Push the MODE button so the “POSITION OUT CAL” LED remains solid **while** the “OPEN” LED flashes. Use the adjust buttons (▲ and ▼) to set the desired output voltage (VDC) or current (mA) on the option module output for the open position.
4. Continue with Step 13 in the **Quick Calibration Procedure** (see above).

FAULT INDICATORS

The DHC-100 detects various fault conditions that prohibit the unit from controlling the actuator. A combination of the three Fault indicators (red, yellow, and green) will turn on or flash to indicate a specific detected fault. Note that a fault condition DOES NOT disable the motor outputs when manually controlling the actuator with the adjust buttons; while useful for troubleshooting, care should be exercised when operating the motor under a fault condition. The OVERRIDE mode can also operate the motor when a fault condition exists (see OVERRIDE MODE in manual).

Note that the indicators may not indicate all the fault conditions that may exist. This means that when the indicated fault is corrected, the unit may display another fault that has not been corrected.

The table below provides a summary of the Fault indications.

RED	YEL	GRN	FAULT
flash	flash	OFF	Motor 1 No Motion (Stall)
flash	OFF	flash	Motor 2 No Motion (Stall)
flash	flash	flash	Double No Motion (Stall)
OFF	OFF	flash	Feedback Alarm
OFF	flash	OFF	Loss of Command
OFF	ON	OFF	Command Out of Range
OFF	flash	flash	Feedback Alarm and Loss of Command
OFF	ON	flash	Feedback Alarm and Command Out of Range

Motor 1 No Motion (Stall) - A fault condition is detected when no actuator motion is detected while the Motor 1 output is turned on. The fault condition will disable the Motor 1 output only, and the fault is cleared when the DHC-100 detects a motion greater than 1.5° in either direction. The fault can be cleared if 1) the command signal commands a Motor 2 operation, 2) manual operation with the adjust buttons results in a motion greater than 1.5°, or 3) a mechanical manual override forces the 1.5° motion, provided the mechanical motion is monitored by the feedback pot.

Motor 2 No Motion (Stall) - A fault is detected when no actuator motion is detected while the Motor 2 output is turned on. The fault can be cleared in the same manner as a Motor 1 Stall (see above).

Double No Motion (Stall) - If the DHC-100 detects no actuator motion in either direction, both motor outputs will be disabled. The command signal cannot clear this condition; only manual operation or a mechanical override can clear the fault. Alternatively, the DHC-100 can be powered off and then on to temporarily clear the fault; however, this practice should be avoided without permanently correcting the cause of such a fault.

Feedback Alarm - A fault condition is detected whenever the feedback signal is out of range (that is, less than 5% of the potentiometer value or more than 95% of the potentiometer value), or when any of the potentiometer connections are broken. Normal operation resumes when the potentiometer is reconnected or back in range.

Loss of Command - If the command signal is disconnected, the fault indication will remain on until the signal is reconnected. See LOSS OF COMMAND in manual for details.

Command Out of Range - If the command signal goes out of range, the fault indication will remain on until the signal is back in range. See LOSS OF COMMAND in manual for details.

PROBLEM	POSSIBLE CAUSES	REMEDIES
No response from unit (All lights are off.)	No power Excessive voltage applied to unit. Blown or missing fuse	Check power source. Replace unit. Replace with appropriate fuse; see "Specifications" in manual.
No response from unit, and no response from the adjust (▲ and ▼) or Mode buttons. (MANUAL / FB POT CAL light is lit solid.)	Jumper wire on J7 terminal block is missing. Auto/Manual station is improperly wired.	Install jumper wire on J7 terminal block. Check wiring on Auto/Manual station; see "Override Mode" in manual.

Quick Cal & Troubleshooting Guide

PROBLEM	POSSIBLE CAUSES	REMEDIES
Actuator rotates valve backwards.	Actuator or valve is mounted incorrectly on coupling. Actuator needs to be reverse acting.	Remount actuator as necessary. Refer to "Close" and "Open" modes in manual.
Actuator does not respond to input signal (all FAULT indicators off).	Closed and open positions are set to the same position.	Set closed and open settings; refer to "Close" and "Open" modes in manual.
Motor 1 or 2 No Motion (Stall) FAULT indicators flash after actuator reaches the fully closed or open position.	Closed or open limit switches set inside the operating range. Torque switches trip due to mechanical end stops set inside the operating range.	Adjust limit switch cams; refer to "Close" and "Open" modes in manual. Adjust mechanical end stops; refer to "Close" and "Open" modes in manual.
AUX CLOSE OUTPUT or AUX OPEN OUTPUT indicators flash. If an OTR-100 or OTR-101 option module is not installed, no remedy is required.	Actuator position is near closed or open.	If an OTR-100 or OTR-101 option module is installed, set Aux Close and Aux Open positions; refer to "Aux Close Output" and "Aux Open Output" modes in manual.
Actuator hunts for position.	Sloppy gear tooth engagement No motor brake or brake slipping Unstable command input signal from PID control loop	Adjust feedback potentiometer gears for tight engagement. Install or repair motor brake. Adjust PID parameters for stable command signal.
Triac output failure (Motor buzzes and overheats.) Perform appropriate remedy, <u>then</u> replace the unit.	Exposure to water from conduit entrance Exposure to water from unsealed actuator housing Exposure to moisture from condensate Corrosion from exposure to salts or acids External power applied to motor connections at J1-1 or J1-3. Motor capacitor is defective, or has incorrect voltage rating. Lightning or power surge.	Install drip loop at conduit entrance. Inspect and/or replace actuator housing gasket; use actuator with proper sealing. Use heater and thermostat and/or desiccant packets. Use corrosion inhibitors and desiccant packets. Remove connector J1 prior to applying external power. Replace motor capacitor. Replace unit.